

PRODUCT NUMBER
SEE TABLE

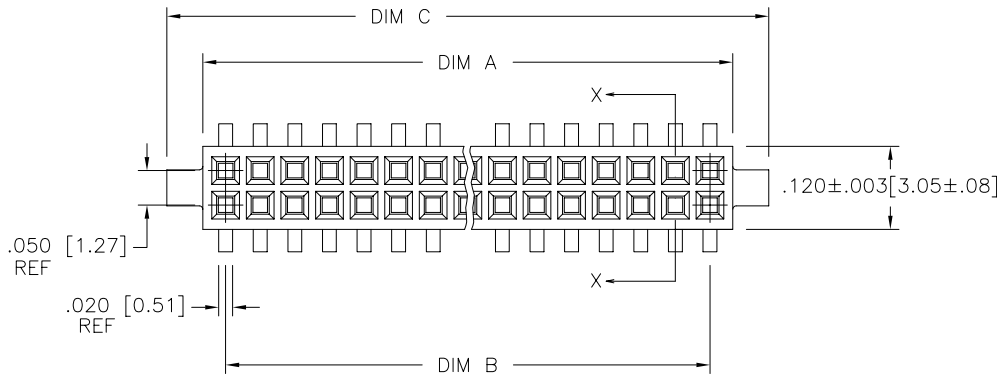

.0400 [1.016]
2X

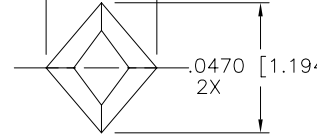

VIEW E-E
SCALE 4/1

.0470 [1.194]

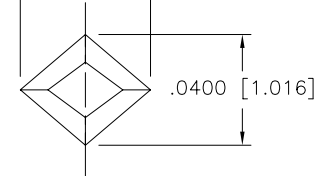

VIEW F-F
SCALE 4/1

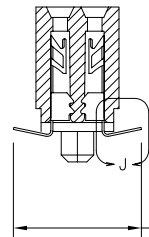
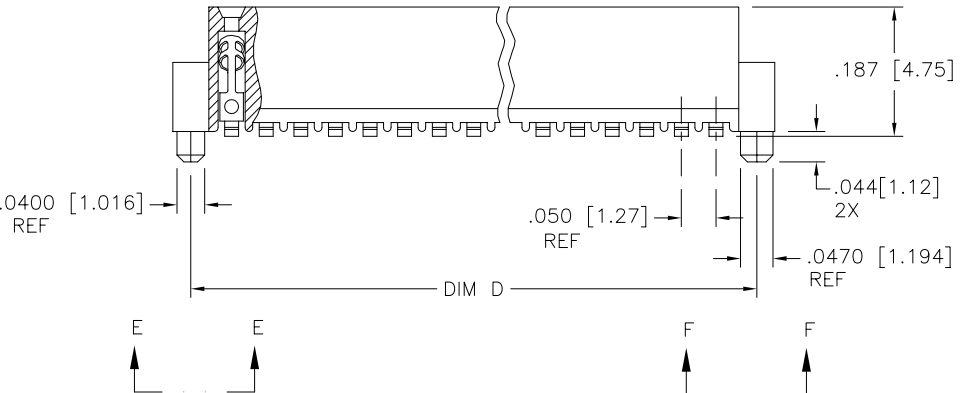

SECTION X-X

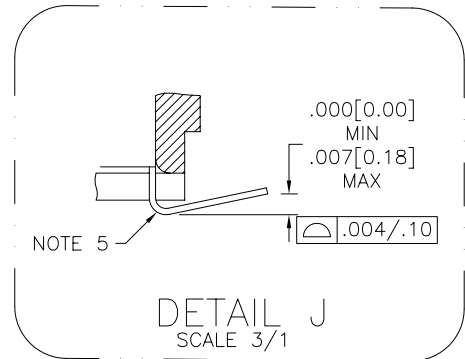

DETAIL J
SCALE 3/1

mat'l. code		surface		tolerance		projection		product family	
-		ISO 1302 ✓		ISO 406 ISO 1101				RIBCAGE	
tolerances unless otherwise specified		angles		linear		INCH/MM		title	
ltr	ecn no	dr	date					.050/1.27cc V.C.C S/M	
C	V91739	EPK	7/27/99		.xx±.01/0.3			W/.044/1.12 SHORT PEG	
D	V10994	DWL	3/9/01		.xxx±.005/0.13			scale 4:1	
E	V11674	CRG	6/14/01	0°±2'	.xxxx±.0020/0.051			dwg no	
F	M05-0123	MHT	6/09/05	dr	M. CLOUSER	6/11/97		sheet 1 of 2	
G	M06-0225	ERE	6/12/06	enfr	D. WHITING	6/11/97		size	
H	M06-0370	MHT	9/25/06	chr	C. GINGRICH	6/11/97		A3	
				appd	D. WHITING	6/11/97		type Product Customer Drawing	
sheet index	revision sheet	H	H						
		1	2						

FCI
FCIconnect.com

Copyright FCI

PRODUCT NUMBER NOTE 6	SIZE	DIM A	DIM B	DIM C	DIM D
73542-605	2 X 5	.266/6.76	.200/5.08	.370/9.40	.3200/8.128
-610	2 X 10	.516/13.11	.450/11.43	.620/15.75	.5700/14.478
-615	2 X 15	.766/19.46	.700/17.78	.870/22.10	.8200/20.828
-620	2 X 20	1.016/25.81	.950/24.13	1.120/28.45	1.0700/27.178
-625	2 X 25	1.266/32.16	1.200/30.48	1.370/34.80	1.3200/33.528
-630	2 X 30	1.516/38.51	1.450/36.83	1.620/41.15	1.5700/39.878
-635	2 X 35	1.766/44.86	1.700/43.18	1.870/47.50	1.8200/46.228
-640	2 X 40	2.016/51.21	1.950/49.53	2.120/53.85	2.0700/52.578
-645	2 X 45	2.266/57.56	2.200/55.88	2.370/60.20	2.3200/58.928
73542-650	2 X 50	2.516/63.91	2.450/62.23	2.620/66.55	2.5700/65.278

NOTES:

- ① HOUSING MATERIAL :
GLASS FILLED THERMOPLASTIC FLAME RETARDANT PER UL 94V-0
COLOR: BLACK
- ② TERMINAL MATERIAL: BeCu
- ③ TERMINAL PLATING:
6XX 30u"/.76u MIN HARD GOLD OVER Ni ON CONTACT ZONES.
100u"/2.54u MIN Sn OVER Ni IN SOLDERING ZONES.
OTHERWISE GOLD FLASH OR UNPLATED.
- 4 APPLICATION INFORMATION:
A. RECOMMENDED MOUNTING PAD PATTERN IS SHOWN IN FIGURE "A".

B. MATING PINS TO BE .0176/.447 TO .0181/.459 THICK.

C. MATING PIN TIPS TO BE IN TRUE POSITION TO MATING GRID WITHIN .006/.15 DIA.

D. SUGGESTED MATING PIN LENGTH .130/3.30 ±.010/.25.
- ⑤ LEAD TIPS TO BE ABOVE HEEL UP TO .007/0.18 MAX.
COPLANARITY TO BE MEASURED AT LOWEST POINT (HEEL).
- ⑥ ADD 'LF' SUFFIX AT THE END OF PART NUMBER FOR LEAD FREE OPTION.
7. THESE PRODUCTS MEET EUROPEAN UNION DIRECTIVES AND OTHER COUNTRY REGULATION AS DESCRIBED IN GS-22-008.
8. THE HOUSING WILL WITHSTAND EXPOSURE TO 260°C PEAK TEMPERATURE FOR 20 SECONDS IN A CONVECTION, INFRA-RED OR VAPOR PHASE REFLOW OVEN. SEE APPLICATION NOTES/PROCEDURES IF THEY ARE AVAILABLE.
9. PACKAGE PER BUS-14-179 IS NO SUFFIX OR "CT" SUFFIX FOLLOWS DASH NUMBER & SEE GS-14-920 FOR LEAD FREE PACKAGING REQUIREMENTS.

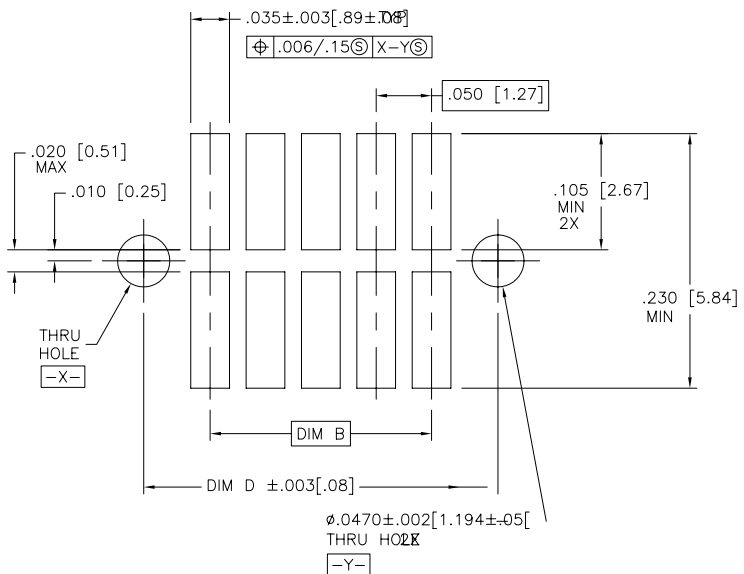

FIGURE A
RECOMMENDED
P.C.B. LAYOUT

mat'l. code		surface		tolerance		projection		product family	
-		ISO 1302 ✓		ISO 406 ISO 1101				RIBCAGE	
ltr	ecn	no	dr	date		tolerances unless otherwise specified		title	
H						angles linear .xx±.01/0.3 .xxx±.005/0.13 .xxxx±.0020/0.051		INCH/MM .050/1.27cc V.C.C S/M W/.044/1.12 SHORT PEG	
						scale 4:1		dwg no 73542	
								sheet 2 of 2 size A3	
								type Product Customer Drawing	
sheet index	revision sheet								